

IS-Machines

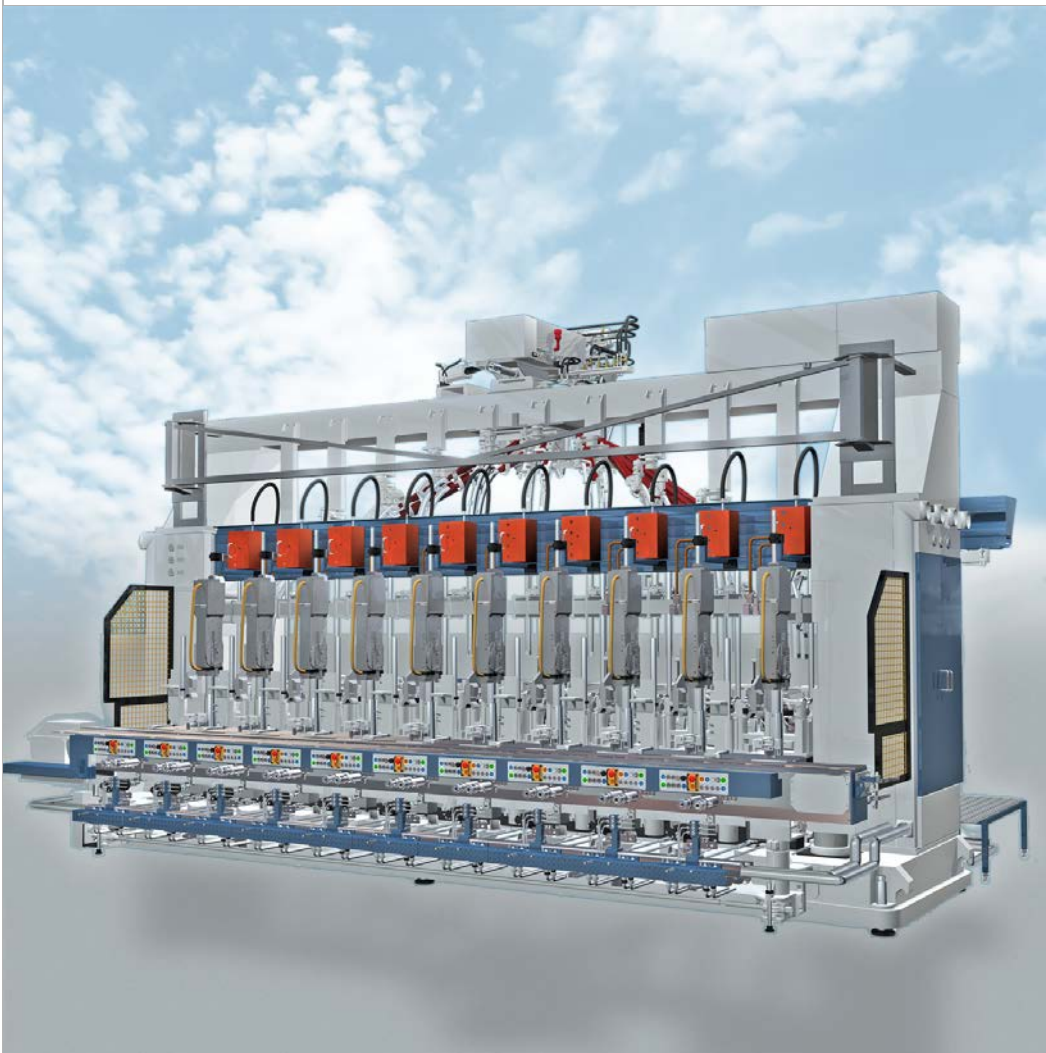

6 Section Machine

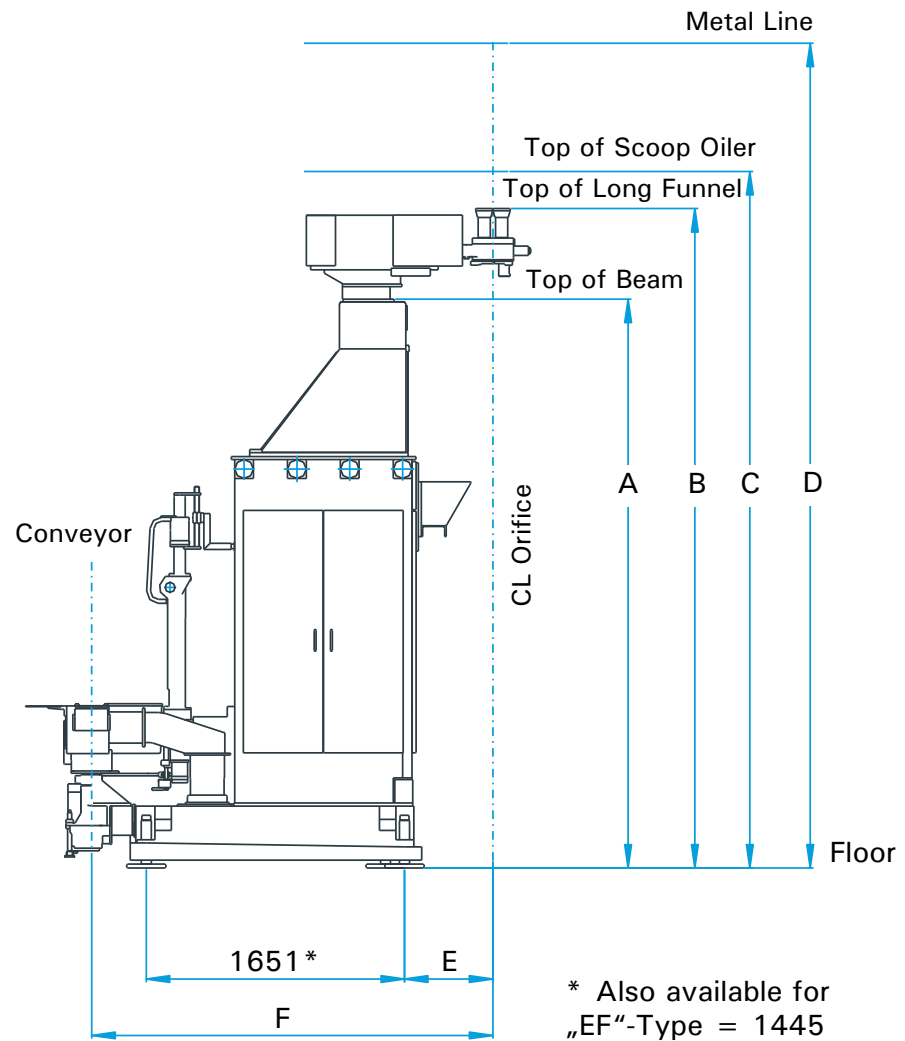

	4¼"	5"	5½"	6"
A [mm]	3203	3203	3203	3203
B [mm]	3783	3783	3783	3783
C [mm]	4023	4023	4023	4023
D [mm]– 81 Standard	4751	–	–	–
– 81 tief	4801	4801	4801	4801
– 503	4843	4843	4843	4843
E [mm]	595	595	565	565
F [mm]	2398	2417	2565	2549

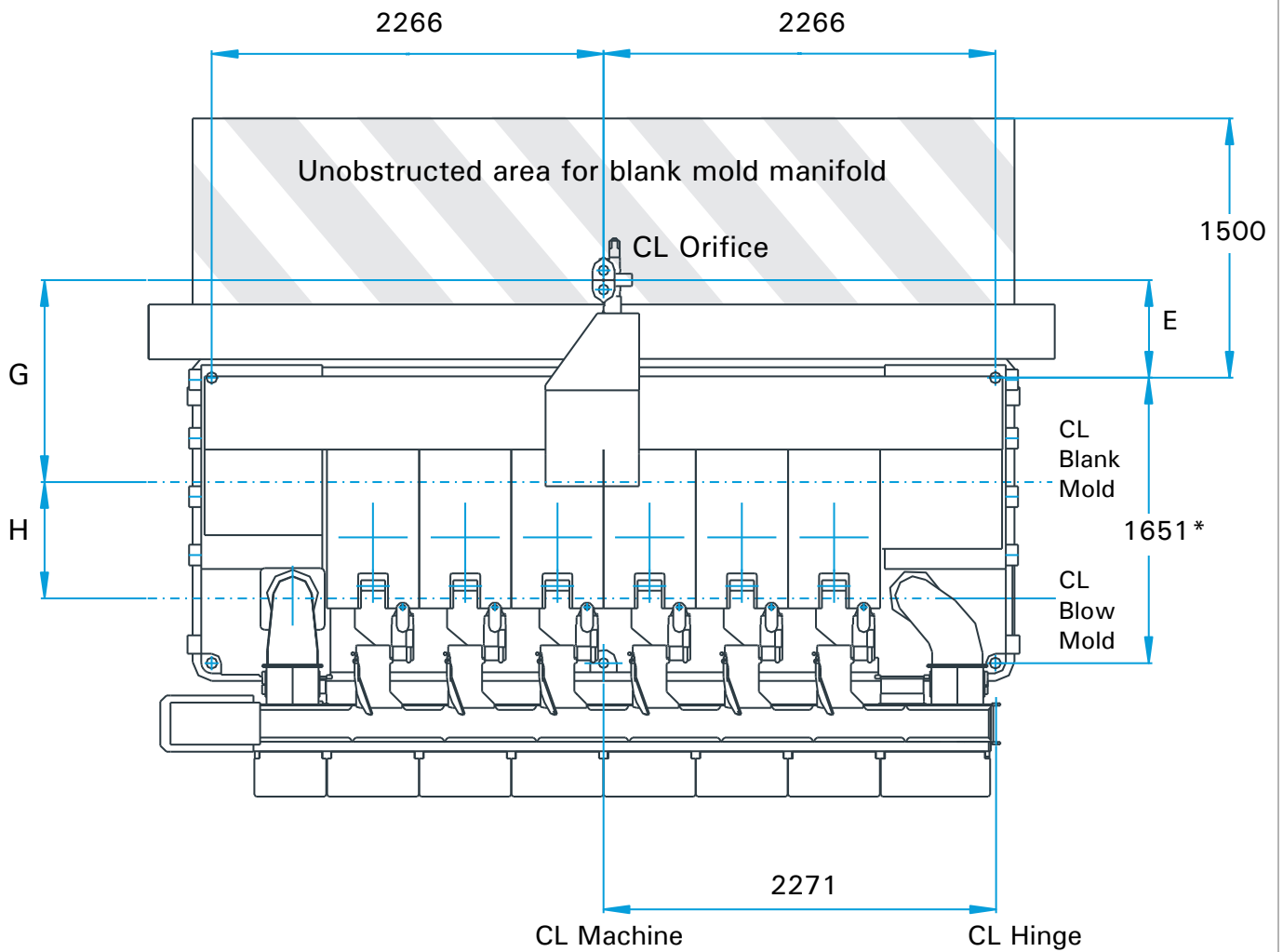

	4¼" DG	5" DG	5½" DG	6" DG
E [mm]	595	595	565	565
G [mm]	1168,4	1158,9	1168,4	1168,4
H [mm]	610,4	629,5	673,5	679,5

8 Section Machine

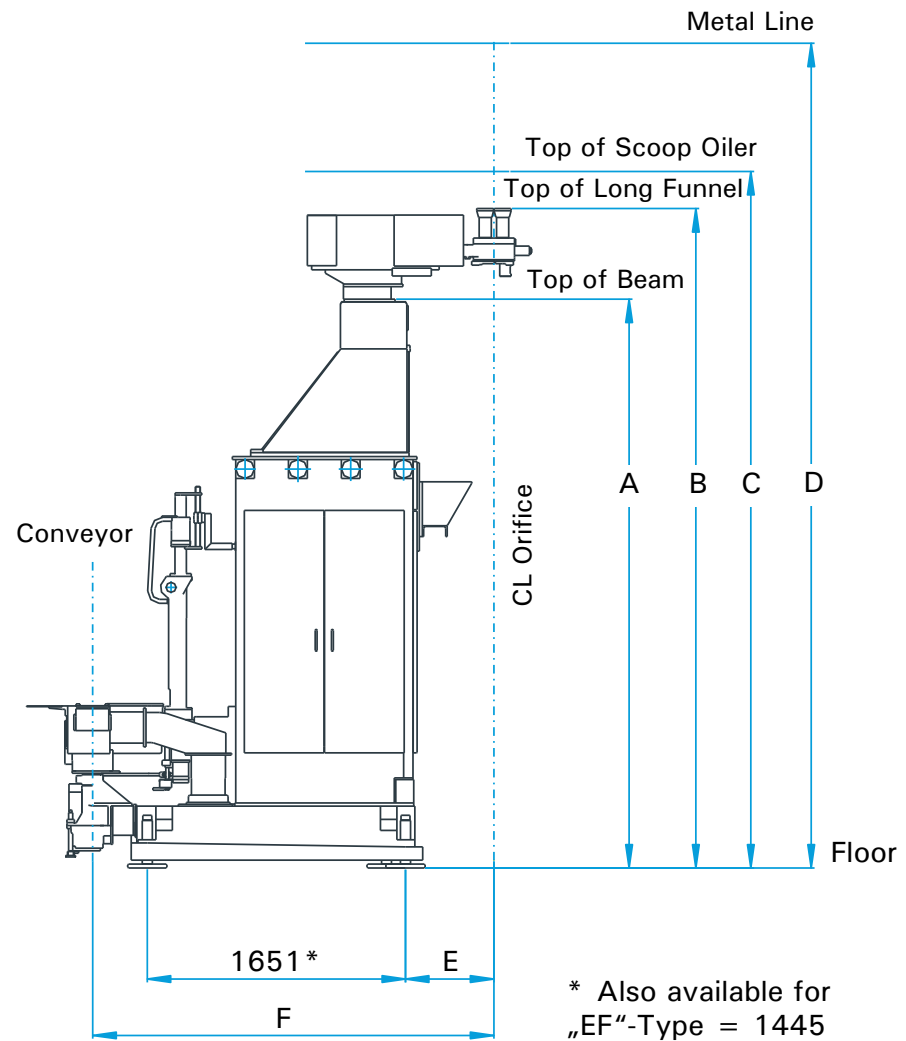

	4¼"	5"	5½"	6"	6¼"
A [mm]	3278	3278	3278	3278	3278
B [mm]	3858	3858	3858	3858	3858
C [mm]	4098	4098	4098	4098	4098
D [mm] – 81 tief	4876	4876	4876	4876	4876
– 503	4918	4918	4918	4918	4918
– 515	4962	4962	4962	4962	4962
E [mm]	597	597	565	565	584
F [mm]	2398	2417	2565	2549	2604

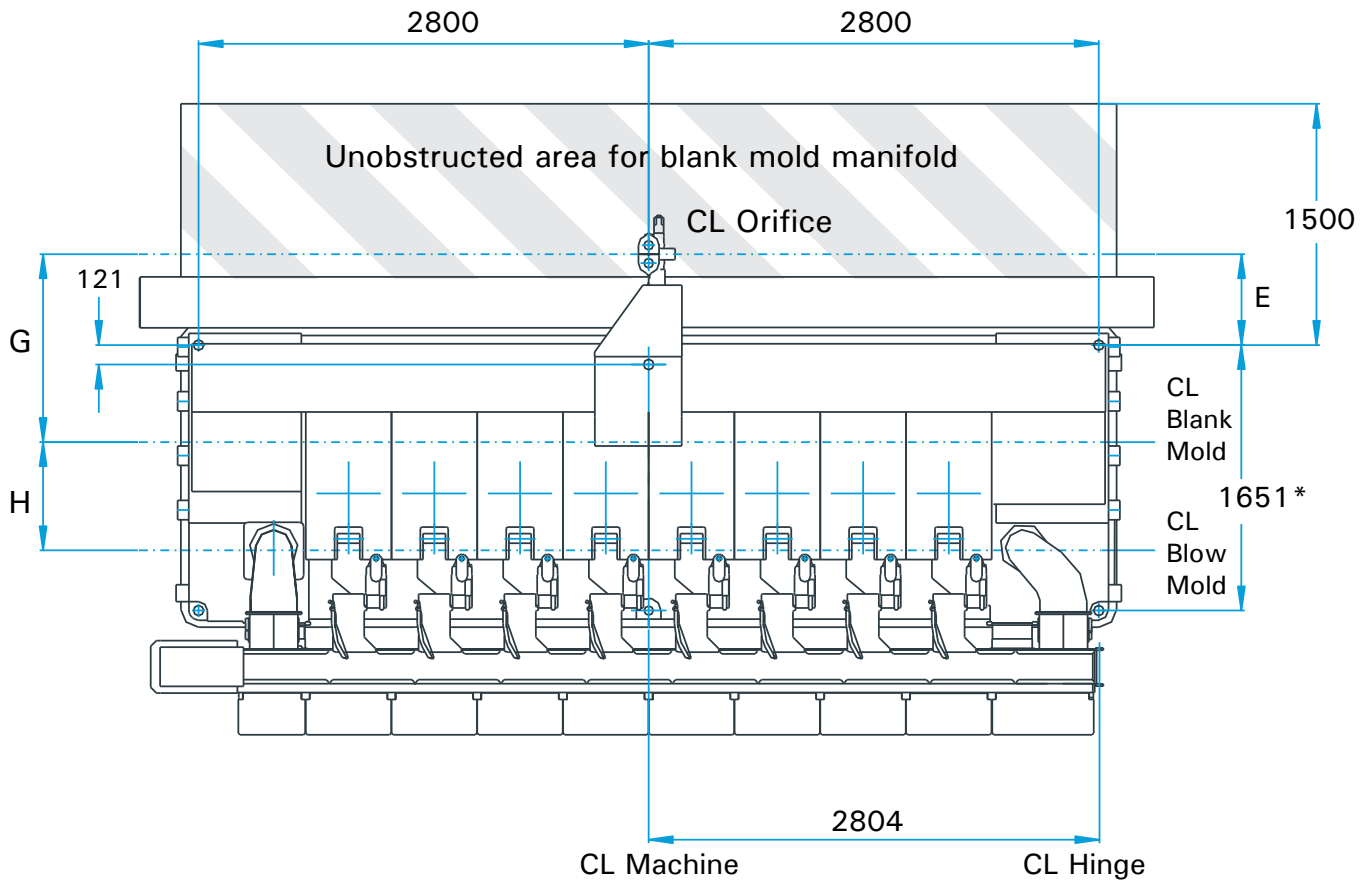

	4¼" DG	5" DG	5½" DG	6" DG	6¼" DG
E [mm]	597	597	565	565	584
G [mm]	1168,4	1158,9	1168,4	1168,4	1168,4
H [mm]	610,4	629,5	673,5	679,5	711,2

10 Section Machine

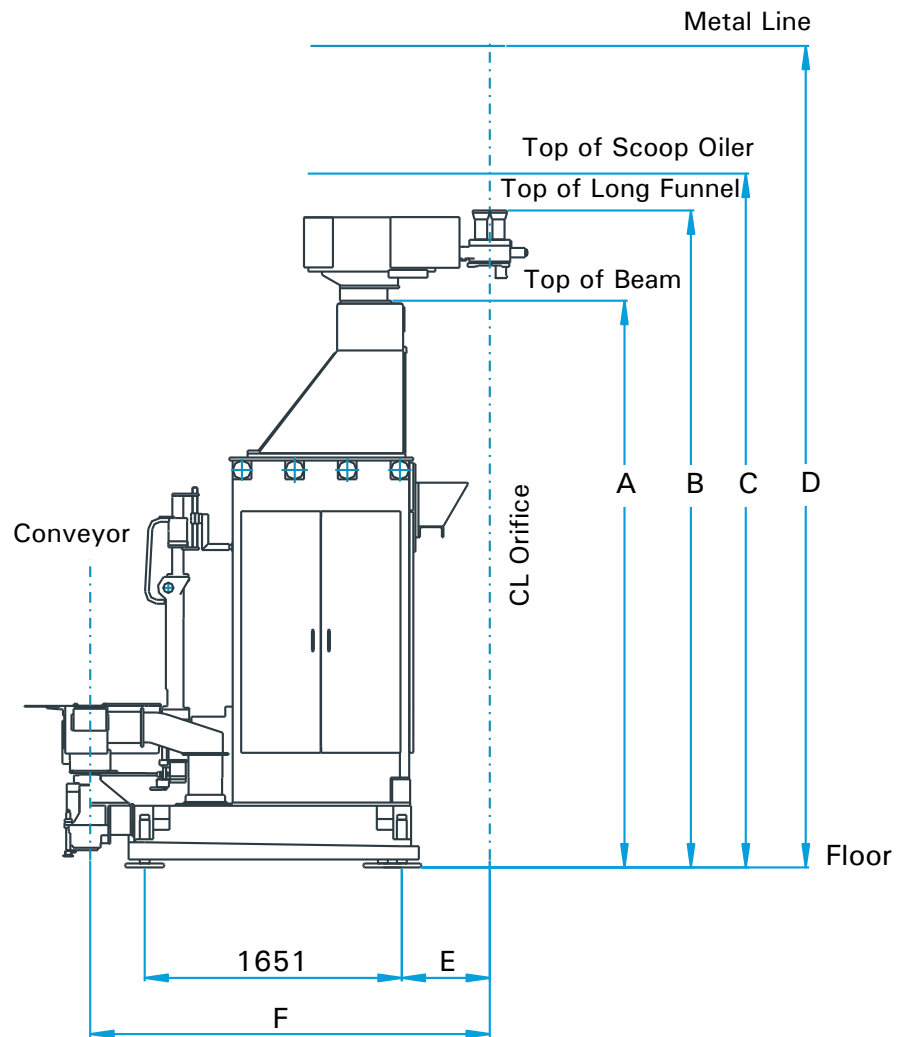

	4¼"	5"	5½"	6"	6¼"
A [mm]	3512	3512	3512	3512	3512
B [mm]	4092	4092	4092	4092	4092
C [mm]	4332	4332	4332	4332	4332
D [mm] – 503	5152	5152	5152	5152	5152
– 515	5196	5196	5196	5196	5196
E [mm]	597	597	565	565	584
F [mm]	2398	2417	2565	2549	2604

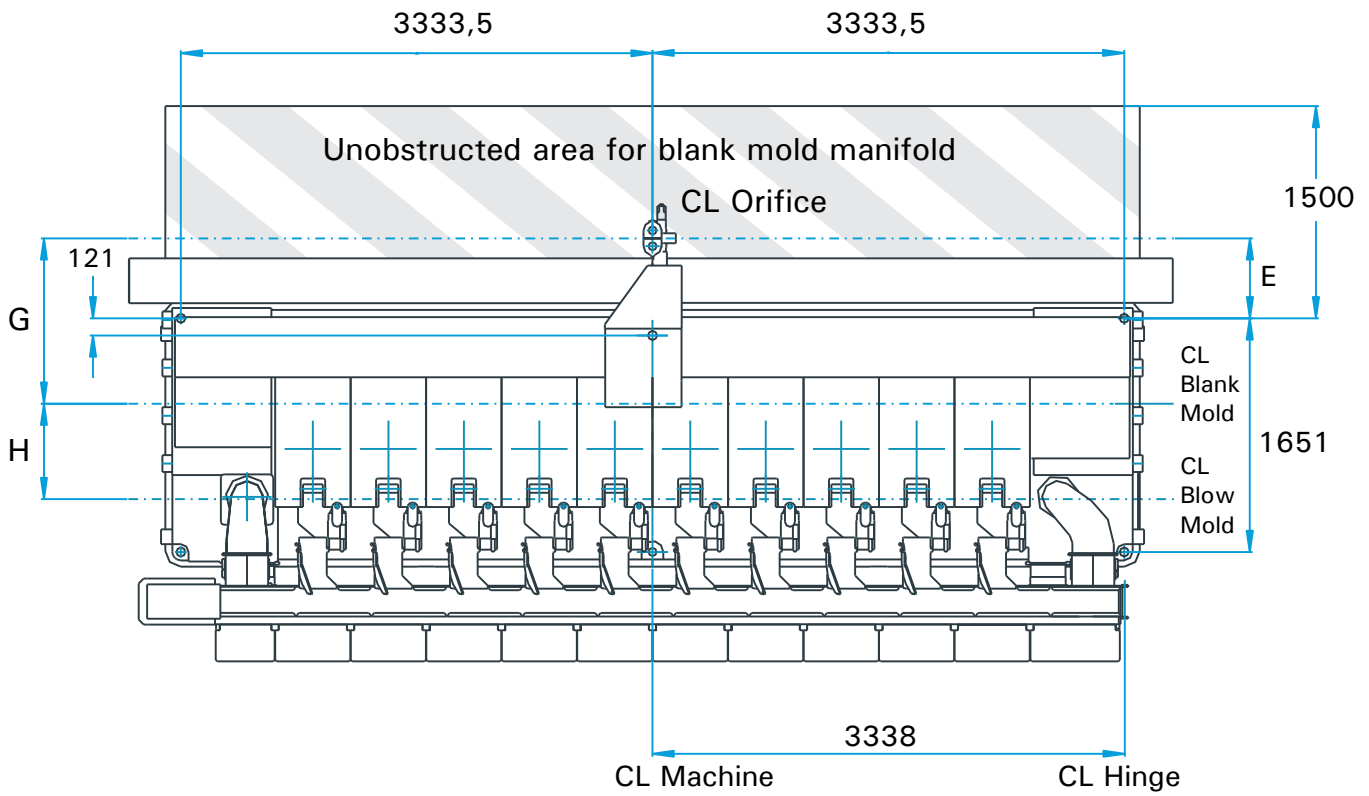

	4¼" DG	5" DG	5½" DG	6" DG	6¼" DG
E [mm]	597	597	565	565	584
G [mm]	1168,4	1158,9	1168,4	1168,4	1168,4
H [mm]	610,4	629,5	673,5	679,5	711,2

12 Section Machine

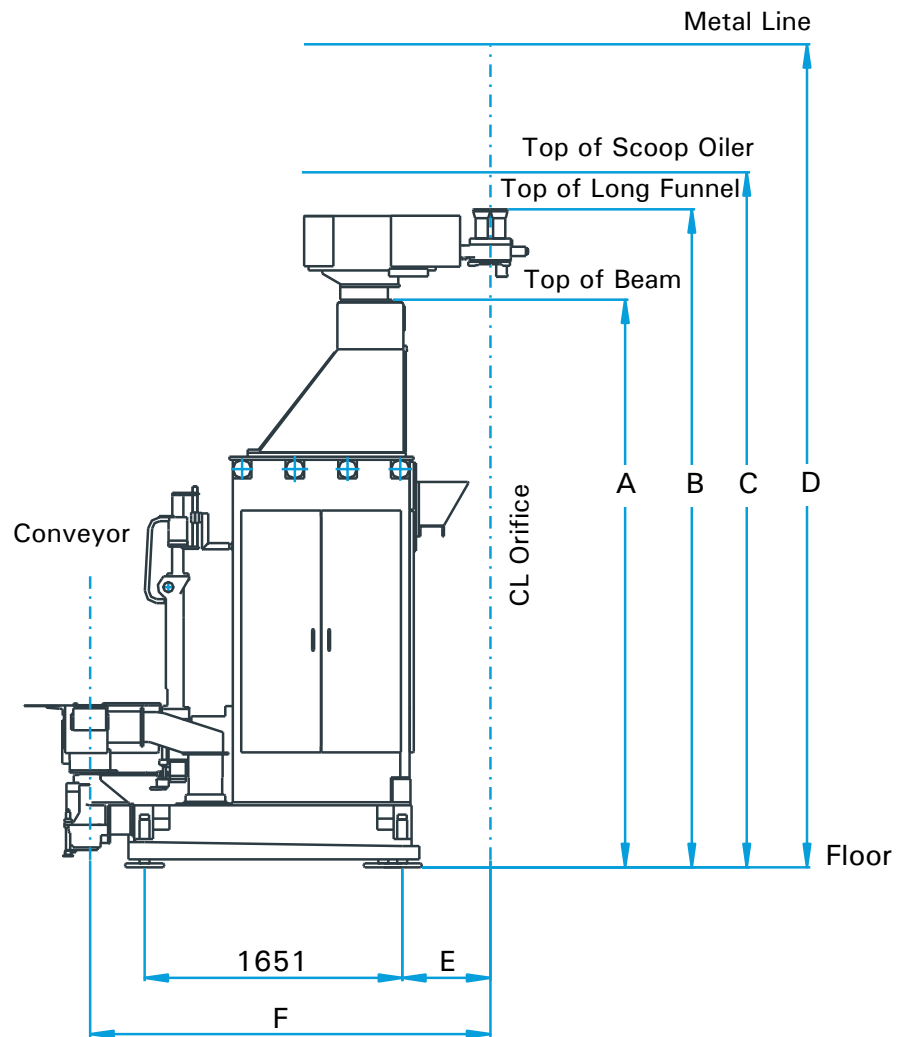

	4¼"	5"	5½"	6"	6¼"
A [mm]	3712	3712	3712	3712	3712
B [mm]	4292	4292	4292	4292	4292
C [mm]	4532	4532	4532	4532	4532
D [mm] – 503	5352	5352	5352	5352	5352
– 515	5396	5396	5396	5396	5396
E [mm]	597	597	565	565	584
F [mm]	2398	2417	2565	2549	2604

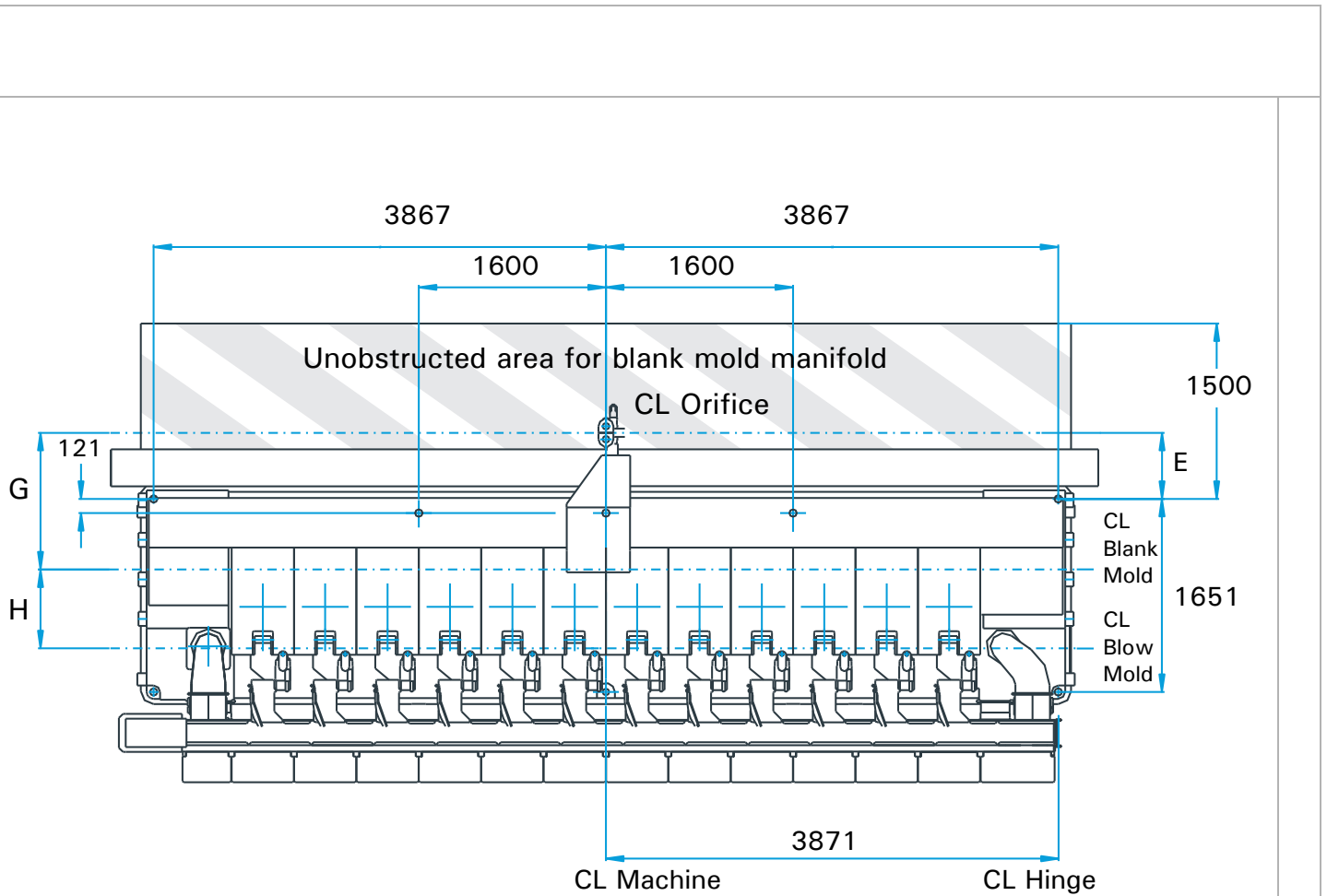

	4¼" DG	5" DG	5½" DG	6" DG	6¼" DG
E [mm]	597	597	565	565	584
G [mm]	1168,4	1158,9	1168,4	1168,4	1168,4
H [mm]	610,4	629,5	673,5	679,5	711,2

2 x 8 Section Machines as Tandem (16 Section Machine)

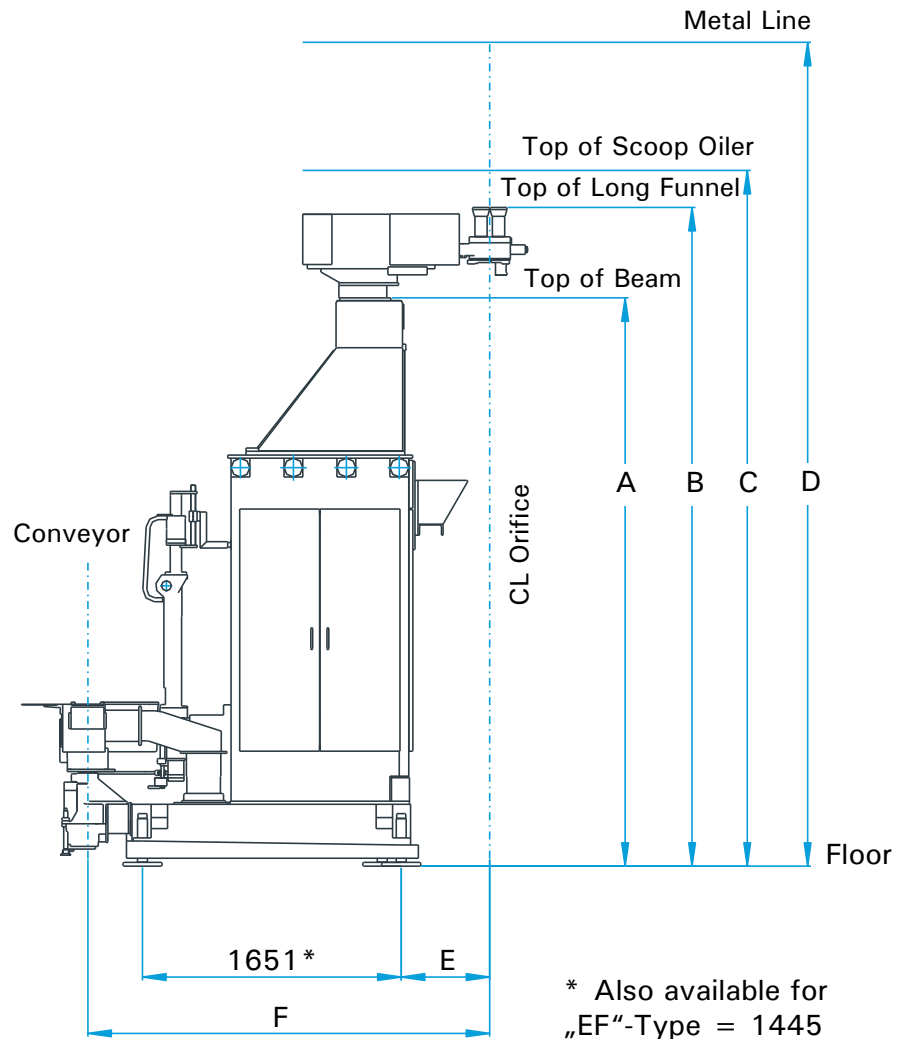

	4¼"	5"	5½"	6"	6¼"
A [mm]	3278	3278	3278	3278	3278
B [mm]	3858	3858	3858	3858	3858
C [mm]	4098	4098	4098	4098	4098
D [mm] – 81 tief	4876	4876	4876	4876	4876
– 503	4918	4918	4918	4918	4918
– 515	4962	4962	4962	4962	4962
E [mm]	597	597	565	565	584
F [mm]	2398	2417	2565	2549	2604

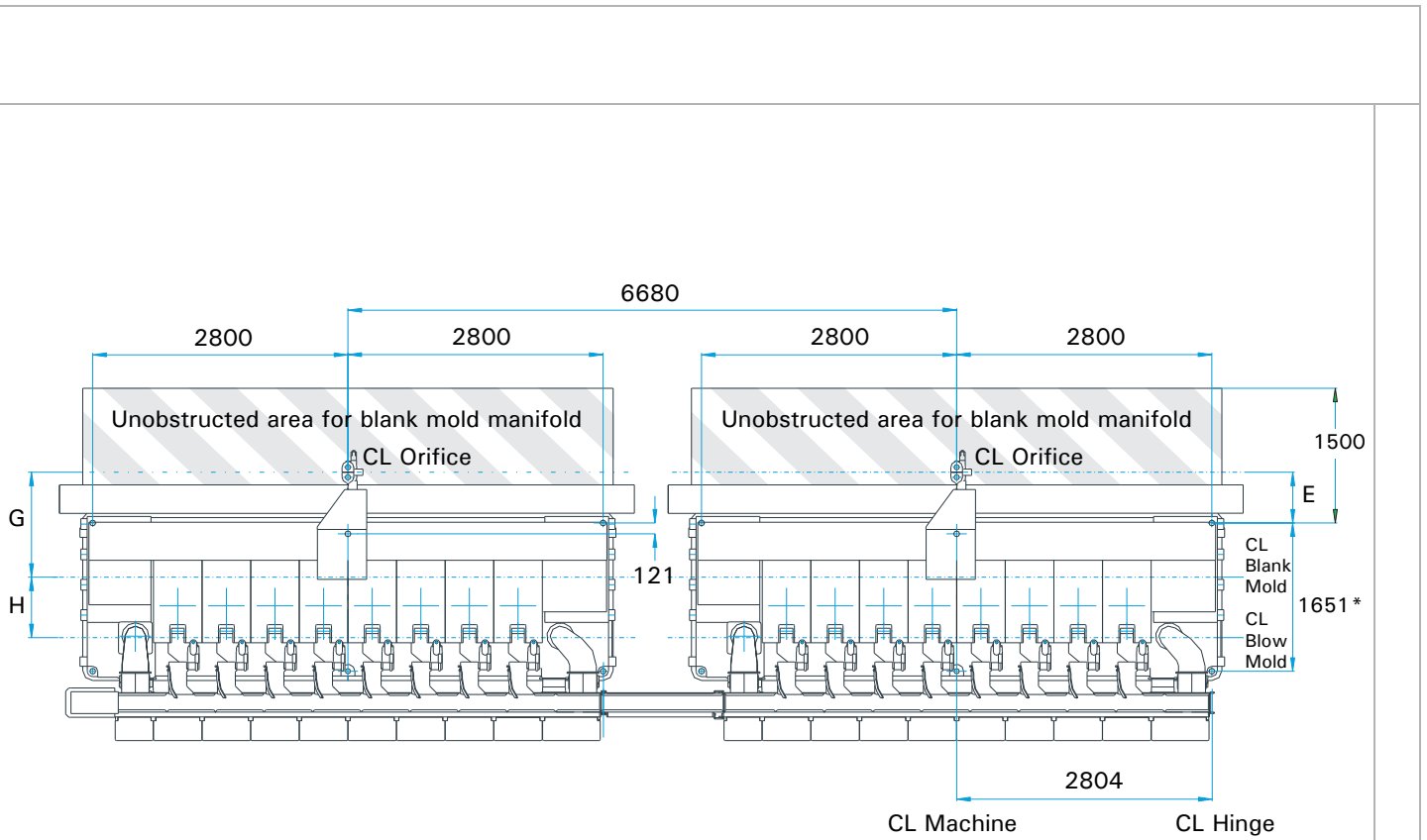

	4¼" DG	5" DG	5½" DG	6" DG	6¼" DG
E [mm]	597	597	565	565	584
G [mm]	1168,4	1158,9	1168,4	1168,4	1168,4
H [mm]	610,4	629,5	673,5	679,5	711,2

